

RUBBER EXPANSION JOINT EPDM THREADED BSP WITH CAST IRON UNION FITTINGS

EPDM expansion joint with cast iron union fittings to absorb vibrations and noises on water distribution, heating and HVAC networks.

Not advisable for hydrocarbons, greasy product and abrasive products.

EPDM double wave body and galvanized cast iron union fittings.

For linear and angular compansion.



Size : DN1/2" to DN3"
Connection : Threaded BSP
Min Temperature : -10°C
Max Temperature : +100°C
Max Pressure : 16 Bars
Specifications : Absorb vibrations and noises
Linear and angular compansion
Double wave EPDM tube

Materials : Galvanized cast iron union fittings

RUBBER EXPANSION JOINT EPDM THREADED BSP WITH CAST IRON UNION FITTINGS

SPECIFICATIONS :

- Absorb vibration, noises and expansion
- Linear and angular compansion
- Double wave EPDM Tube (EPDM marking)
- Galvanized cast iron union fittings

Marking example (EPDM):



USE :

- Water distribution, heating and HVAC
- Min and max Temperature Ts : - 10°C to + 100°C
- Max Pressure Ps : 16 bars (see graph)

PRESSURE / TEMPERATURE GRAPH (STEAM EXCLUDED) :

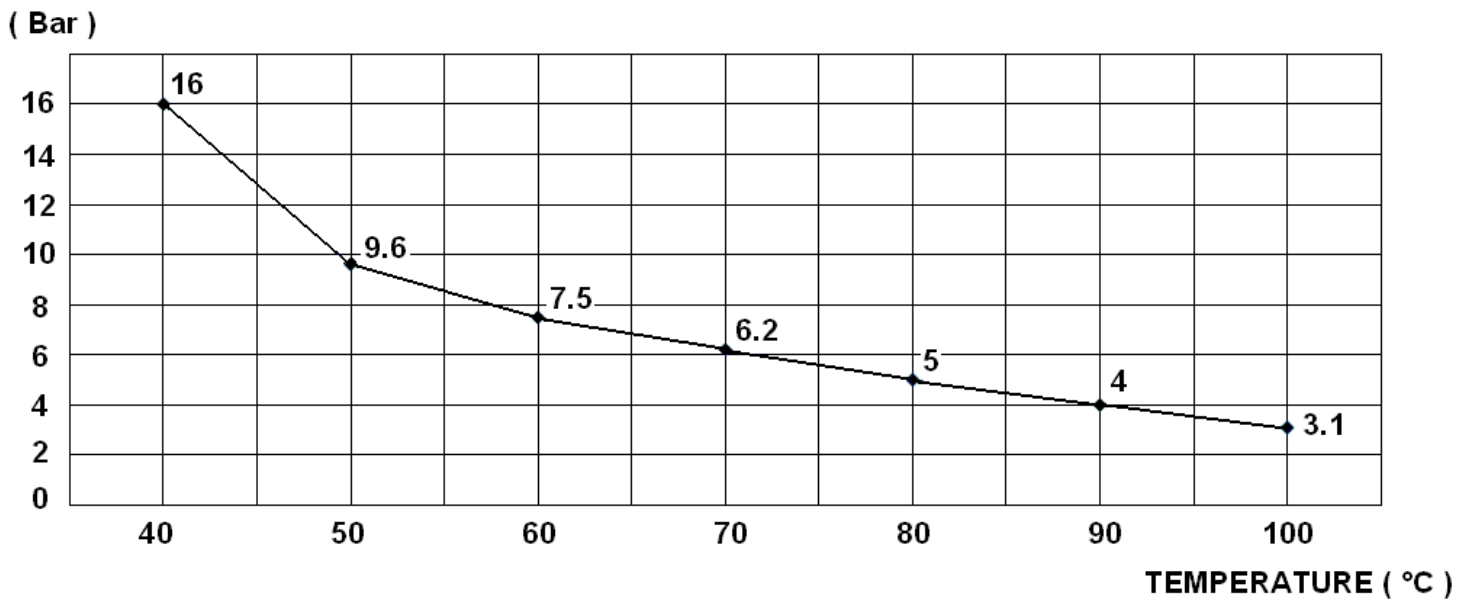

RANGE :

- EPDM expansion joint threaded BSP with cast iron union fittings from DN 1/2" to DN 3" Ref. 1504

RUBBER EXPANSION JOINT EPDM THREADED BSP WITH CAST IRON UNION FITTINGS

MATERIALS :

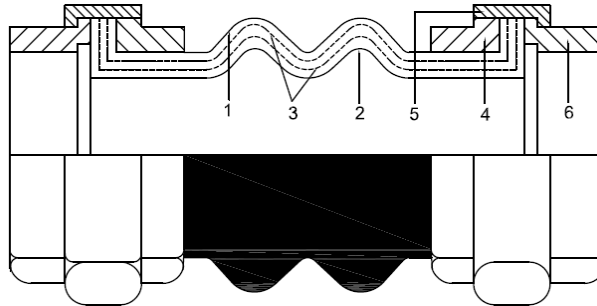

Item	Designation	Materials
1-2	Inner tube and cover	EPDM
3	Reinforcement	Nylon cord
4-5-6	Fittings	Galvanized cast iron

SIZE (in mm) :

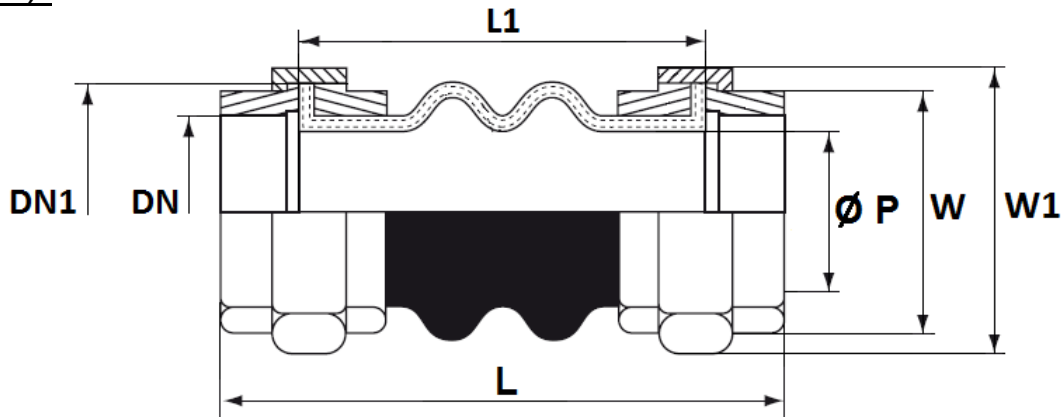

DN	1/2"	3/4"	1"	1"1/4	1"1/2	2"	2"1/2	3"
DN1	M42	M42	M52	M60	M68	M82	M98	M115
L	200	200	200	200	200	200	240	240
L1	151	151	150	143	137	130	166	156
Ø P	14	16	21	25	32	42	58	62
W (on flat)	27	33	41	50	55	69	85	97
W1 (on flat)	49	49	60	70	79	95	113	127
Weight (Kg)	0.6	0.55	0.85	1.25	1.6	2.4	3.5	5.2
Ref.	1504004	1504005	1504006	1504007	1504008	1504009	1504010	1504011

RUBBER EXPANSION JOINT EPDM THREADED BSP WITH CAST IRON UNION FITTINGS

MOVEMENTS (in mm) :

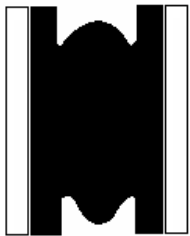

Compansion



Expansion

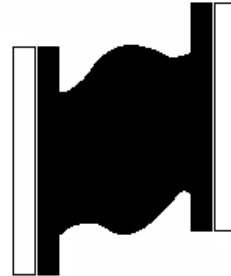

Lateral

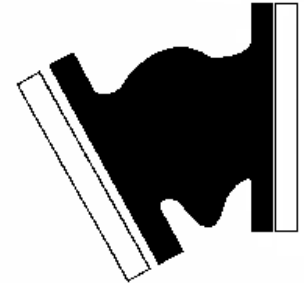

Angular

DN	1/2"	3/4"	1"	1"1/4	1"1/2	2"	2"1/2	3"
Compansion	22	22	22	22	22	22	22	22
Expansion	6	6	6	6	6	6	6	6
Lateral	22	22	22	22	22	22	22	22
Angular	30°	30°	30°	30°	30°	20°	15°	15°

Maximum movements can't be applied together

STANDARDS :

- Manufacturer certified ISO 9001 : 2015
- DIRECTIVE 2014/68/EU : Products excluded from directive (Article 4, § 3)
- Threaded BSP conical fittings according to ISO 7/1 Rc
- Approval certificate **Marine LLOYD'S REGISTER**

ADVICE : Our opinion and our advice are not guaranteed and SFERACO shall not be liable for the consequences of damages. The customer must check the right choice of the products with the real service conditions.